

LT9211D --- Product Brief

MIPI to 2-Port LVDS Converter

1. Features

- **Dual-Port LVDS Transmitter**
 - Compatible with VESA and JEIDA standard
 - 1~2 configurable port
 - 1 clock lane and 4 data lanes per port
 - Two port simultaneous display supported
 - Resolution up to 3840x2160 30Hz or any other resolution with pixel clock between 6.25MHz to 297MHz
 - Support DE and SYNC mode
 - Programmable pre-emphasis
 - Support output SSC(30KHz±5%)
- **MIPI Receiver**
 - Compliant with DCS1.02, D-PHY1.2 , DSI1.2 and CSI-2 1.00
 - 1 clock lane and 1~4 configurable data lanes
 - 80Mb/s ~ 2.5Gb/s per data lane
 - Resolution up to 3840x2160 30Hz or any other resolution with pixel clock between 6.25MHz to 297MHz
 - Both non-burst and burst video mode supported
 - Support RGB666, loosely RGB666, RGB888, RGB565, 16-bit YCbCr4:2:2 video format

- **Miscellaneous**

- Support 100KHz and 400KHz I2C slave
- External 25MHz ± 50ppm crystal reference clock is preferred

2. General Description

LT9211D is a high performance MIPI DSI/CSI-2 to Dual-Port LVDS convertor. LT9211D deserializes input MIPI video data, decodes packets, and converts the formatted video data stream to LVDS transmitter output between AP and mobile display panel or camera. LT9211D support maximum 12.5dB input equalization and programmable pre-emphasis to improve performance.

3. Applications

- Mobile systems
- Cellular handsets
- Digital video cameras
- Digital still cameras
- Tablet PC, Notebook PC
- Car Display and Camera System

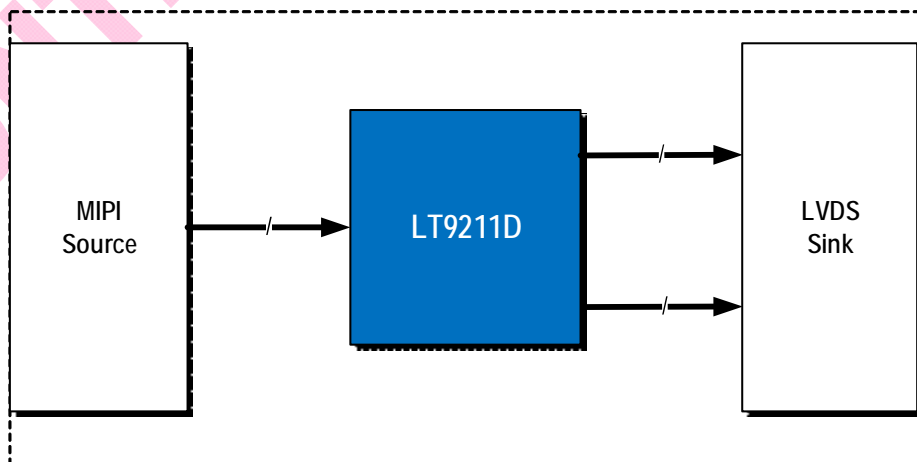

Figure 3.1 LT9211D Typical Application Diagram

4. Ordering Information

Table 4.1 Ordering Information

Product Name	Part Number	Product Status	Package	Bonding Wire	Grade	Operating Temperature Range	Stack Die Option	Packing Method	MPQ
LT9211D	LT9211D_U2Q07CEN	Preview	QFN64 (7.5*7.5) Saw	Cu	E	-40°C to +85°C	N	Tray	2600pcs

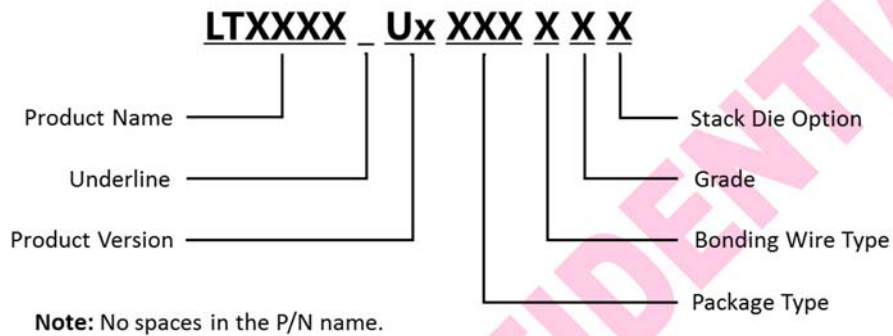

Figure 4.1 Part Number Naming Rules

Copyright © 2022-2023 Lontium Semiconductor Corporation, All rights reserved.

Lontium Semiconductor Proprietary & Confidential

This document and the information it contains belong to Lontium Semiconductor. Any review, use, dissemination, distribution or copying of this document or its information outside the scope of a signed agreement with Lontium is strictly prohibited.

LONTIUM DISCLAIMS ALL WARRANTIES, EXPRESSED OR IMPLIED, INCLUDING THOSE OF NONINFRINGEMENT, MERCHANTABILITY, TITLE AND FITNESS FOR A PARTICULAR PURPOSE. CUSTOMERS EXPRESSLY ASSUME THEIR OWN RISK IN RELYING ON THIS DOCUMENT.

LONTIUM PRODUCTS ARE NOT DESIGNED OR INTENDED FOR USE IN LIFE SUPPORT APPLIANCES, DEVICES OR SYSTEMS WHERE A MALFUNCTION OF A LONTIUM DEVICE COULD RESULT IN A PERSONAL INJURY OR LOSS OF LIFE.

Lontium assumes no responsibility for any errors in this document, and makes no commitment to update the information contained herein. Lontium reserves the right to change or discontinue this document and the products it describes at any time, without notice. Other than as set forth in a separate, signed, written agreement, Lontium grants the user of this document no right, title or interest in the document, the information it contains or the intellectual property it embodies.

Trademarks

Lontium™ 龙迅™ and ClearEdge™ is a registered trademark of Lontium Semiconductor. All other brand names, product names, trademarks, and registered trademarks contained herein are the property of their respective owners.

Visit our corporate web page at: www.lontiumsemi.com

Technical support: support@lontium.com

Sales: sales@lontium.com