

LT8644EX --- Product Brief

Digital Crosspoint Switch

1. Features

- 250Mbps to 6 Gbps per port NRZ data rate
- Programmable receive equalization, compensates 40 inches of FR4 at 6Gbps
- DC- or AC-coupled differential CML inputs
- DC- or AC-coupled differential CML outputs
- Programmable CML output levels and pre-emphasis levels
- Support output polarity swap
- 50Ω on-chip I/O termination
- Supports 8b/10b, scrambled or uncoded NRZ data
- Integrated 100/400kHz I2C slave
- Low power consumption
- Power supply: 3.3V for I/O and 1.2V for core
- ESD 4kV HBM
- Temperature Range: -40°C ~ +85°C
- 128-pin QFN 14*14 package

2. General Description

The LT8644EX is a 16×16 digital crosspoint switch, with 16 differential CML compatible inputs and 16 differential CML outputs. The LT8644EX is optimized for non return-to-zero (NRZ) signaling with data rates of up to 6 Gbps per port. Each port offers programmable level of input equalization and programmable output swing. The LT8644EX supports independent channel switching through the serial control interface. The LT8644EX has low latency and very low channel-to-channel skew. An I2C interface is used to control the device and provide access to advanced features.

3. Applications

- Fiber optic network switching
- Digital video (HDMI, DVI, Display Port)
- Data storage networks

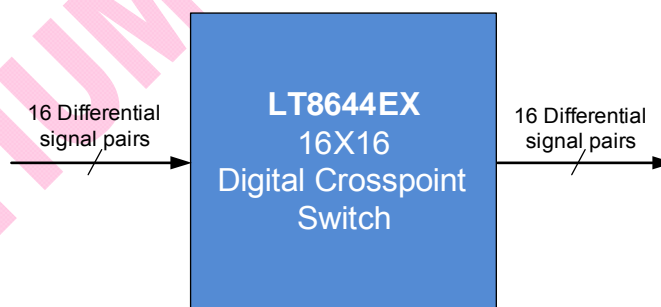

Figure 3.1 Application Diagram

4. Ordering Information

Table 4.1 Ordering Information

Product Name	Part Number	Product Status	Package	Bonding Wire	Grade	Operating Temperature Range	Stack Die Option	Packing Method	MPQ
LT8644EX	LT8644EX_U1Q00CEN	Preview	QFN128 (14*14)Saw	Cu	E	-40°C to +85°C	N	Tray	1190pcs

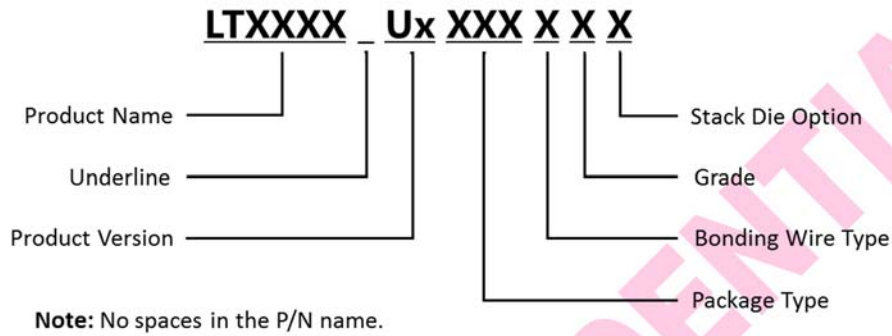

Figure 4.1 Part Number Naming Rules

Copyright © 2022 Lontium Semiconductor Corporation, All rights reserved.

Lontium Semiconductor Proprietary & Confidential

This document and the information it contains belong to Lontium Semiconductor. Any review, use, dissemination, distribution or copying of this document or its information outside the scope of a signed agreement with Lontium is strictly prohibited.

LONTIUM DISCLAIMS ALL WARRANTIES, EXPRESSED OR IMPLIED, INCLUDING THOSE OF NONINFRINGEMENT, MERCHANTABILITY, TITLE AND FITNESS FOR A PARTICULAR PURPOSE. CUSTOMERS EXPRESSLY ASSUME THEIR OWN RISK IN RELYING ON THIS DOCUMENT.

LONTIUM PRODUCTS ARE NOT DESIGNED OR INTENDED FOR USE IN LIFE SUPPORT APPLIANCES, DEVICES OR SYSTEMS WHERE A MALFUNCTION OF A LONTIUM DEVICE COULD RESULT IN A PERSONAL INJURY OR LOSS OF LIFE.

Lontium assumes no responsibility for any errors in this document, and makes no commitment to update the information contained herein. Lontium reserves the right to change or discontinue this document and the products it describes at any time, without notice. Other than as set forth in a separate, signed, written agreement, Lontium grants the user of this document no right, title or interest in the document, the information it contains or the intellectual property it embodies.

Trademarks

Lontium™ 龙迅™ and ClearEdge™ is a registered trademark of Lontium Semiconductor. All other brand names, product names, trademarks, and registered trademarks contained herein are the property of their respective owners.

Visit our corporate web page at: www.lontiumsemi.com

Technical support: support@lontium.com

Sales: sales@lontium.com