

LT6911UXE --- Product Brief

HDMI2.0 to Dual-Port MIPI DSI/CSI with Audio

1. Features

● HDMI2.0 Receiver

- Compliant with HDMI2.0b, HDMI1.4 and DV11.0
- Compliant with HDCP2.3 and HDCP1.4
- Data rate up to 6Gbps
- Adaptive receiver equalization
- AC-couple capable
- Support 4k@60Hz
- Supported deep color: 8/10/12 bpc
- Support CEC
- HDR support
- Support TMDS descrambling for EMI/RFI reduction
- Support SCDC
- 5V tolerance DDC/HPD I/Os
- Integrated EDID shadow

● Single/Dual-Port MIPI DSI/CSI Transmitter

- Compliant with DCS1.1, D-PHY1.2 & DSI1.3 & CSI-2 1.3
- 1/2 configurable ports
- 1 clock lane and 1/2/3/4 configurable data lanes per port
- 80Mbps~2.5Gbps per data lane
- Programmable transmitter swing and pre-emphasis
- Support lane swap(arbitrarily) and polarity inversion(independent)
- 3D support: two ports simultaneously transmitting side by side alternative pixels
- DSI support both burst mode and non-burst mode
- DSI support 16/20/24-bit YCbCr4:2:2, 24/30-bit RGB, 12-bit YCbCr4:2:0, CSI support RGB888/666, YUV422 8/10-bit
- Maximum 64 pixels overlap for each half
- Video stream copy mode for each port

● Digital Audio Output

- I2S interface supporting 2-channel audio, with sample rates of 32~192 kHz and sample sizes of 16~24 bits

- SPDIF interface supporting PCM, Dolby Digital, DTS digital audio at up to 192kHz frame rate
- IEC60958 or IEC61937 compatible

● Miscellaneous

- CSC: RGB <-> YUV444 <-> YUV422
- External oscillator 24MHz
- Integrated microprocessor
- Embedded SPI flash for firmware and HDCP keys
- GPIOs for system controls
- Integrated 100/400kHz I2C slave
- Firmware update through I2C interface
- Power supply: 3.3V for I/O and 1.2V for core
- Temperature Range: -40°C ~ +85°C
- Package: QFN64(7.5mm*7.5mm)
- Pin compatible with LT6911UXC

2. General Description

The LT6911UXE is a high performance HDMI2.0 to MIPI DSI/CSI converter for VR, Smart phone, Display applications.

The HDMI2.0 input supports data rate up to 6Gbps which provides sufficient bandwidth for 4k@60Hz video. Also HDCP2.3 is supported for data decryption.

For MIPI DSI/CSI output, LT6911UXE features configurable single-port or dual-port MIPI DSI/CSI with 1 high-speed clock lane, and 1~4 high-speed data lanes operating at maximum 2.5Gbps/lane, which can support a total bandwidth of up to 20Gbps. LT6911UXE supports burst mode DSI video data transferring, also supports flexible video data mapping path. Two digital audio output interfaces are available, I2S and SPDIF. The I2S interface supports 2-ch LPCM and the SPDIF interface supports 2-ch LPCM or compressed audio, both at maximum 192kHz sample rate.

The device is capable of automatic operation which is

enabled by an integrated microprocessor that uses an embedded SPI flash for firmware storage. System control is also available through the configuration I2C slave interface.

3. Applications

- Mobile system
- Display
- VR

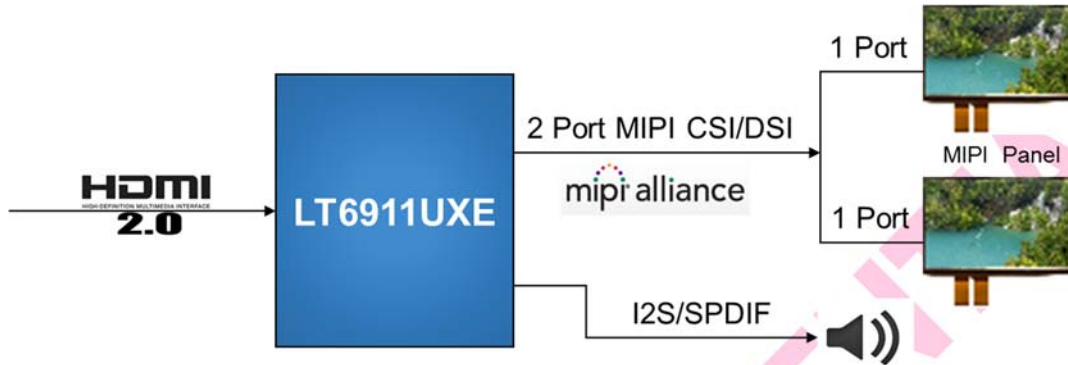

Figure 3.1 Application Diagram

4. Ordering Information

Table 4.1 Ordering Information

Product Name	Part Number	Product Status	Package	Bonding Wire	Grade	Operating Temperature Range	Stack Die Option	Packing Method	MPQ
LT6911UXE	LT6911UXE_U1Q07CED	MP	QFN64 (7.5*7.5) Saw	Cu	E	-40°C to +85°C	D	Tray	2600pcs

MP: Mass Production.

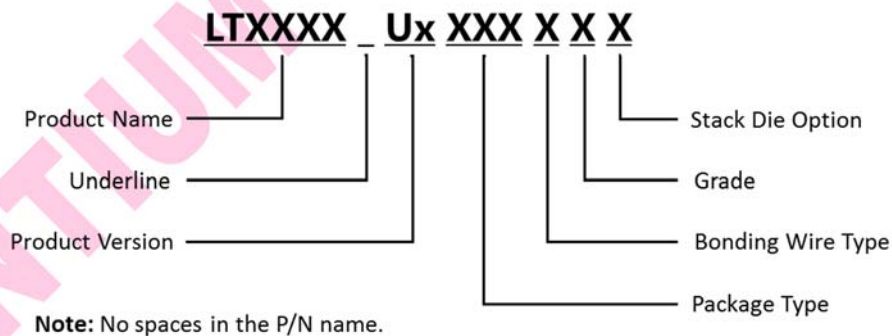

Figure 4.1 Part Number Naming Rules

Copyright © 2021-2022 Lontium Semiconductor Corporation, All rights reserved.

Lontium Semiconductor Proprietary & Confidential

This document and the information it contains belong to Lontium Semiconductor. Any review, use, dissemination, distribution or copying of this document or its information outside the scope of a signed agreement with Lontium is strictly prohibited.

LONTIUM DISCLAIMS ALL WARRANTIES, EXPRESSED OR IMPLIED, INCLUDING THOSE OF NONINFRINGEMENT, MERCHANTABILITY, TITLE AND FITNESS FOR A PARTICULAR PURPOSE. CUSTOMERS EXPRESSLY ASSUME THEIR OWN RISK IN RELYING ON THIS DOCUMENT.

LONTIUM PRODUCTS ARE NOT DESIGNED OR INTENDED FOR USE IN LIFE SUPPORT APPLIANCES, DEVICES OR SYSTEMS WHERE A MALFUNCTION OF A LONTIUM DEVICE COULD RESULT IN A PERSONAL INJURY OR LOSS OF LIFE.

Lontium assumes no responsibility for any errors in this document, and makes no commitment to update the information contained herein. Lontium reserves the right to change or discontinue this document and the products it describes at any time, without notice. Other than as set forth in a separate, signed, written agreement, Lontium grants the user of this document no right, title or interest in the document, the information it contains or the intellectual property it embodies.

Trademarks

Lontium™ 龙迅™ and ClearEdge™ is a registered trademark of Lontium Semiconductor. All other brand names, product names, trademarks, and registered trademarks contained herein are the property of their respective owners.

Visit our corporate web page at: www.lontiumsemi.com

Technical support: support@lontium.com

Sales: sales@lontium.com