

# LT8711V --- Product Brief

## Type-C/DP1.2 to VGA Converter with Audio

### Features

- **USB Type-C**
  - Compliant with VESA DisplayPort Alt Mode on USB Type-C standard V1.0
  - Compliant with USB Power Delivery specification R2.0, V1.0
  - Compliant with USB Type-C Cable and Connector specification R1.2
  - Compliant with HDMI 1.4b Alt Mode on USB Type-C specification V1.0
  - Compliant with DP Alt Mode 1.0, PD 2.0, Type-C 1.2, HDMI1.4b Alt Mode 1.0
  - Built-in dual CC controllers for charger and normal communication
  - 3 data roles supported: DFP, UFP and DRP
  - 2 power roles supported: source and sink
- **DP1.2 Receiver**
  - Compliant with VESA DP1.2 and Embedded DisplayPort (eDP) v1.4
  - No HDCP decryption
  - 1/2 configurable data lanes
  - 1.62/2.7/5.4Gbps per data lane
  - Support SSC
  - 1Mbps AUX channel
  - Receiver PHY is HDMI signal compatible
  - Adaptive or programmable receiver equalization
  - Support lane swap(arbitrarily) and polarity inversion(independent)
  - Support 4k@30Hz
  - Support eDP Authentication: Alternative Scramble Seed Reset and Alternative Framing
  - Fast and full Link Training for Embedded DisplayPort system
- **Triple-Channel Video DAC**
  - Compliant with VESA VSIS1.2
  - 200MSPS throughput and WUXGA timing support
  - Amplitude calibration
  - R/B swappable
  - Load sensing
  - 5V tolerance DDC I/Os
- **Digital Audio Input/Output**
  - Up to four I2S interface supporting 8-channel audio, with sample rates of 32~192 kHz and sample sizes of 16~24 bits
  - SPDIF interface supporting PCM, Dolby Digital, DTS digital audio at up to 192kHz frame rate
  - IEC60958 or IEC61937 compatible
- **Miscellaneous**
  - DP receiver to VGA bypass to support HDMI Alt Mode
  - Support Swift Charge
  - USB billboard module integrated
  - Internal or external oscillator
  - Integrated microprocessor
  - Embedded SPI flash for firmware
  - GPIOs for VBUS/VCONN/AUX and other system controls
  - Integrated 100/400kHz I2C slave
  - Firmware update through SPI, I2C, AUX or USB interface
  - Low power consumption
  - Power supply: 3.3V for I/O and 1.2V for core
  - Embedded 5V to 3.3V LDO
  - ESD 4kV HBM
  - Temperature range: -40°C ~ +85°C
  - Package : 6mmx6mm QFN48

### Description

The LT8711V is a high performance Type-C/DP1.2 to VGA converter, designed to connect a USB Type-C source or a DP1.2 source to a VGA sink.

The LT8711V integrates a DP1.2 compliant receiver, and a high-speed triple-channel video DAC. Also, two CC controllers are included for CC communication to implement DP Alt Mode and power delivery function, one for upstream Type-C port and another for downstream port.

Two digital audio output interfaces are available, I2S and SPDIF. The I2S interface supports 2-ch LPCM and the SPDIF interface supports 8-ch LPCM or compressed audio, both at maximum 192kHz sample rate.

The device is capable of automatic operation which is enabled by an integrated microprocessor that uses an

embedded SPI flash for firmware storage. System control is also available through the use of a dedicated configuration I2C slave interface.

LT8711V also support EDID buffer, DP/eDP input detection and determine to enter into power saving mode automatically. When the receiver of LT8711V locks the input signal, the MCU can read the recovered timing parameters by the MSA registers to match the ASSR. The DPCD registers are accessible via system I2C when debugging the full link training. Once the fast link training used, system time will save at least 400ms.

## Applications

- Docking Station
- Dongle

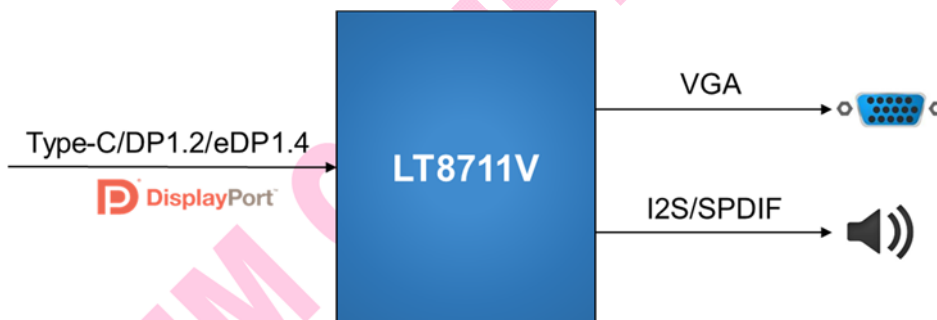

Figure 1. Application Diagram

## Ordering Information

Part Number	Operating Temperature Range	Package	Packing Method
LT8711V	-40°C to+85°C	QFN48 (6*6)	Tray

**Copyright © 2017 Lontium Semiconductor Corporation, All rights reserved.**

### **Lontium Semiconductor Proprietary & Confidential**

This document and the information it contains belong to Lontium Semiconductor. Any review, use, dissemination, distribution or copying of this document or its information outside the scope of a signed agreement with Lontium is strictly prohibited.

LONTIUM DISCLAIMS ALL WARRANTIES, EXPRESSED OR IMPLIED, INCLUDING THOSE OF NONINFRINGEMENT, MERCHANTABILITY, TITLE AND FITNESS FOR A PARTICULAR PURPOSE. CUSTOMERS EXPRESSLY ASSUME THEIR OWN RISK IN RELYING ON THIS DOCUMENT.

LONTIUM PRODUCTS ARE NOT DESIGNED OR INTENDED FOR USE IN LIFE SUPPORT APPLIANCES, DEVICES OR SYSTEMS WHERE A MALFUNCTION OF A LONTIUM DEVICE COULD RESULT IN A PERSONAL INJURY OR LOSS OF LIFE.

Lontium assumes no responsibility for any errors in this document, and makes no commitment to update the information contained herein. Lontium reserves the right to change or discontinue this document and the products it describes at any time, without notice. Other than as set forth in a separate, signed, written agreement, Lontium grants the user of this document no right, title or interest in the document, the information it contains or the intellectual property in embodies.

### **Trademarks**

Lontium™ 龙迅™ and ClearEdge™ is a registered trademark of Lontium Semiconductor. All Other brand names, product names, trademarks, and registered trademarks contained herein are the property of their respective owners.

**Visit our corporate web page at: [www.lontiumsemi.com](http://www.lontiumsemi.com)**

**Technical support: [support@lontium.com](mailto:support@lontium.com)**

**Sales: [sales@lontium.com](mailto:sales@lontium.com)**