

LT9711B --- Product Brief

Dual-Port MIPI/LVDS to DP1.2 with Type-C

1. Features

● MIPI/LVDS Receiver

- Compliant with D-PHY v1.2, DSI v1.3, CSI-2 v1.3 and DCS v1.02.00 for MIPI
- Compliant with VESA and JEIDA LVDS Specification
- 1~2 Configurable Port
- 1 Clock Lane and 1~4 Configurable Data Lanes
- 80Mb/s~2Gb/s per Data Lane
- Internal Rterm Calibration with Less than 5% Error
- Programmable Equalization
- Burst Mode and Non-Burst Mode Supported for MIPI
- Dual Port Odd-Even Mode and Left-Right Mode Supported
- Support up to 24-bit RGB and YUV Data Format

● DP1.2 Transmitter

- Compliant to VESA DP1.2 Standard
- Support Four Lanes with 1.62Gbps (RBR), 2.7Gbps (HBR) or 5.4Gbps (HBR2) Data Rate
- Support Resolution up to 4Kx2K@60Hz
- Support HDCP1.3 Encryption
- Support 8-bit Deep Color
- Support Hot-Plug Detect
- Optional SSC 0.5% Down-Spreading Output
- Configurable Output Swing for Optimized EMI
- Internal Rterm Calibration with Less than 5% Error
- Support Backlight Control for eDP
- Support ASSR for eDP
- Build-in Pattern Generation

● USB Type-C

- Compatible with USB Type-C R1.2, DP Alt Mode V1.0 and USB PD R3.0
- Roles Supported: DFP and UFP for DCC, UFP for UCC
- Power Roles Supported: SRC, SNK and DRP for DCC, SNK for UCC

- USB Full-Featured, Orientation and Role Detection
- 3-level Current Ability Advertise (Host Mode) or Detection (Device Mode) for Type-C Power: USB Default, 1.5A@5V, 3A@5V
- Support FR_Swap
- SBU Data Path Control for DP Alt Mode
- Dead Battery Support When No Power Applied
- Support Standby Mode for Low-Power Operating

● Miscellaneous

- Support SPDIF and 8-CH I2S Audio Input
- Support DSC v1.2 Bypass Transmission
- Support OSD display with 8K Programmable Dot Matrix and Attribute Table
- 1.2V/1.8V/3.3V Supply Power
- External 27MHz Crystal Reference Clock
- Temperature Range: -40°C to +85°C
- Packaged in 5mm x 5mm BGA81

2. General Description

The Lontium LT9711B is Dual-Port MIPI/LVDS to DP1.2 converter with internal Type-C Alternate Mode switch and PD controller.

The MIPI DSI/CSI input features configurable single-port or dual-port with 1 clock lane, and 1~4 data lanes operating at maximum 2Gbps/lane, which can support a total bandwidth up to 16Gbps. LT9711B supports both burst mode and non-burst mode DSI video data transferring.

For DP1.2 output, it consists of 4 data lanes, supporting RBR (1.62Gbps), HBR (2.7Gbps) and HBR2 (5.4Gbps) link speeds. The build-in optional SSC function reduces EMI effect on EMI-concerned system application.

In order to be adaptable to the USB Type-C ecosystem, LT9711B integrates CC logic and PD management unit to relieve mobile system design complexity and BOM cost. The

switch function is compliant with VESA DP Alternate Mode on USB Type-C Standard.

The LT9711B is fabricated in advanced CMOS process and implemented in a small outline 5x 5mm BGA81 package. This package is RoHS compliant and specified to operate from -40°C to +85°C.

3. Applications

- Mobile systems, VR/AR
- Cellular handsets, PAD/Tablets
- Digital video cameras and Digital still cameras

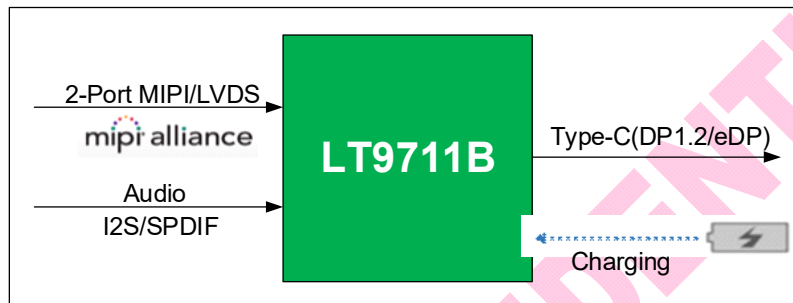

Figure 3.1 Application Diagrams

4. Ordering Information

Table 4.1 Ordering Information

Part Number	Operating Temperature Range	Package	Packing Method	MPQ
LT9711B	-40°C to +85°C	BGA81(5*5)	Tray	4900pcs



Copyright © 2018-2021 Lontium Semiconductor Corporation, All rights reserved.

Lontium Semiconductor Proprietary & Confidential

This document and the information it contains belong to Lontium Semiconductor. Any review, use, dissemination, distribution or copying of this document or its information outside the scope of a signed agreement with Lontium is strictly prohibited.

LONTIUM DISCLAIMS ALL WARRANTIES, EXPRESSED OR IMPLIED, INCLUDING THOSE OF NONINFRINGEMENT, MERCHANTABILITY, TITLE AND FITNESS FOR A PARTICULAR PURPOSE. CUSTOMERS EXPRESSLY ASSUME THEIR OWN RISK IN RELYING ON THIS DOCUMENT.

LONTIUM PRODUCTS ARE NOT DESIGNED OR INTENDED FOR USE IN LIFE SUPPORT APPLIANCES, DEVICES OR SYSTEMS WHERE A MALFUNCTION OF A LONTIUM DEVICE COULD RESULT IN A PERSONAL INJURY OR LOSS OF LIFE.

Lontium assumes no responsibility for any errors in this document, and makes no commitment to update the information contained herein. Lontium reserves the right to change or discontinue this document and the products it describes at any time, without notice. Other than as set forth in a separate, signed, written agreement, Lontium grants the user of this document no right, title or interest in the document, the information it contains or the intellectual property it embodies.

Trademarks

Lontium™ 龙迅™ and ClearEdge™ is a registered trademark of Lontium Semiconductor. All other brand names, product names, trademarks, and registered trademarks contained herein are the property of their respective owners.

Visit our corporate web page at: www.lontiumsemi.com

Technical support: support@lontium.com

Sales: sales@lontium.com